



BIMINI

900260FBN-NWA

BIMINI 60" FAN

DETAILS	
FAN FINISH:	Brushed Nickel
BLADE COUNT:	3
SLOPE DEGREE:	23

DIMENSIONS	
WIDTH:	60"
HEIGHT:	15"

LIGHT SOURCE	
VOLTAGE:	120v

MOUNTING	
CANOPY:	6" Dia.
LEAD WIRE:	1 X 76"

SHIPPING	
CARTON LENGTH:	27
CARTON WIDTH:	12
CARTON HEIGHT:	10

BIMINI

PRODUCT DETAILS:

- This item includes a 4.5" down rod (other lengths of down rods are available)
- An optional light kit is available
- Control your fan's power, light, speed, direction, and so much more from the Hinkley Home Automation app
- Can be hung on a sloped ceiling
- Fan Control included, HIRO Control - 3 Speed Non-Reversing. All-in-one HIRO remote controls power, speed, and lighting; use as a wall control or portable remote
- Accessory controls are available that are compatible with your home's WiFi network
- Merging the best of traditional and modern elements with a sophisticated and streamlined look
- Blades, controls, switches, capacitors and hardware carry a 1-year warranty

HINKLEY

HINKLEY
33000 Pin Oak Parkway
Avon Lake, OH 44012

PHONE: (440) 653-5500
Toll Free: 1 (800) 446-5539

hinkley.com

BIMINI 60" FAN

900260FBN-NWA

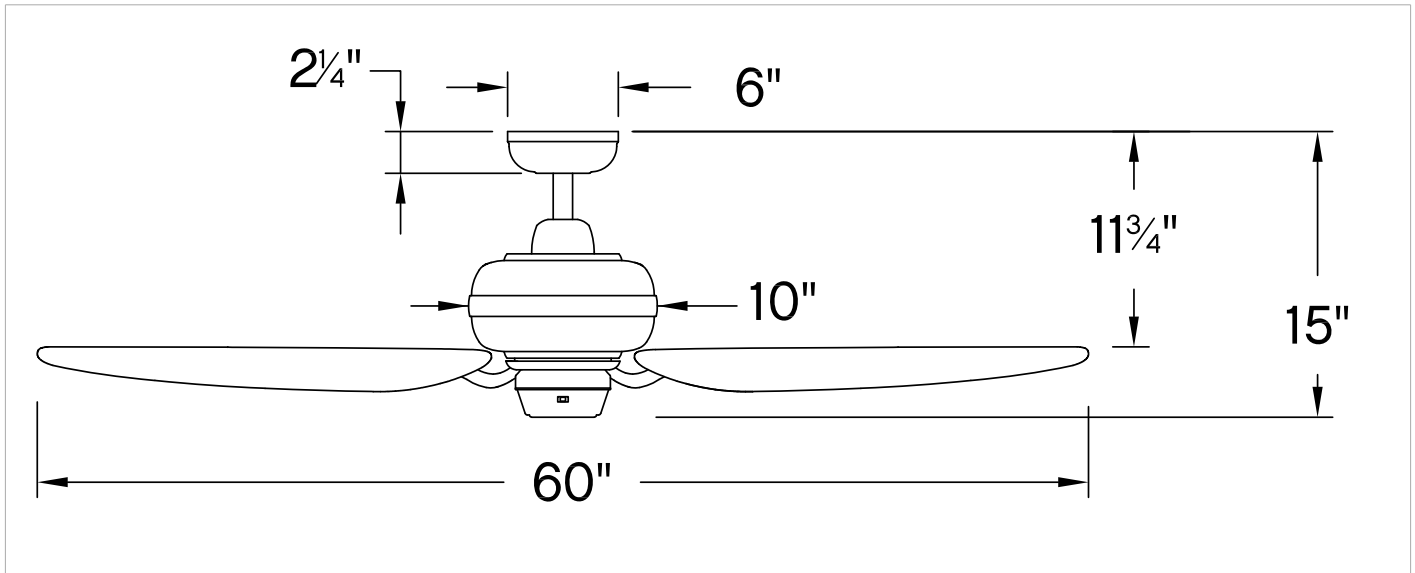

PERFORMANCE SPECIFICATIONS	STANDARD	
	HIGH SPEED	AVERAGE SPEED
Airflow	5902	4118
EnergyUse	61.2	39.4
EnergyCost	17	11
Efficiency	96	105
AMPS	0.53	0.39
RPMS	150	102

AVERAGE PERFORMANCE AND ENERGY INFORMATION

ENERGYGUIDE

Estimated Yearly Energy Cost

\$11

Cost Range of Similar Models (19" – 84")

\$3 | | | \$34

- Based on 12 cents per kWh and 6.4 hours use per day
- Your cost depends on rates and use
- Energy Use: 39.4 Watts

Airflow

4,118

Cubic Feet Per Minute

- The higher the airflow, the more air the fan will move
- Airflow Efficiency: 105 Cubic Feet Per Minute Per Watt

All estimates based on typical use, excluding lights ftc.gov/energy

Airflow Shown is a Weighted Average of High and Low Cubic Feet per Minute Based on Downrod

HINKLEY

HINKLEY
33000 Pin Oak Parkway
Avon Lake, OH 44012

PHONE: (440) 653-5500
Toll Free: 1 (800) 446-5539

hinkley.com