

# QUENTIN

## 4814DZ

### LARGE OPEN FRAME PENDANT

Quentin is constructed of angular forms that create a striking geometric interplay. This stem-hung collection features intersecting rectangles in a bold Aged Zinc finish, forming a modern silhouette. Candle sleeves in Antique Nickel add a distinctively vintage feel that is both hip and historical.

DETAILS	
FINISH:	Aged Zinc
MATERIAL:	Steel
SLOPE DEGREE:	90
DIMMABLE:	YES - WITH DIMMABLE LAMP (NOT INCLUDED)

DIMENSIONS	
WIDTH:	17"
HEIGHT:	19.8"
DEPTH:	17
WEIGHT:	11lb

LIGHT SOURCE	
LIGHT SOURCE:	Socketed
WATTAGE:	4-5w Cand. LED, 60w Equiv. or 4-60w Cand.
VOLTAGE:	120v

MOUNTING	
CANOPY:	4.75" Sq.
LEAD WIRE:	1 X 120"
MAX HEIGHT:	52.8

SHIPPING	
CARTON LENGTH:	19
CARTON WIDTH:	11
CARTON HEIGHT:	23
CARTON WEIGHT:	14

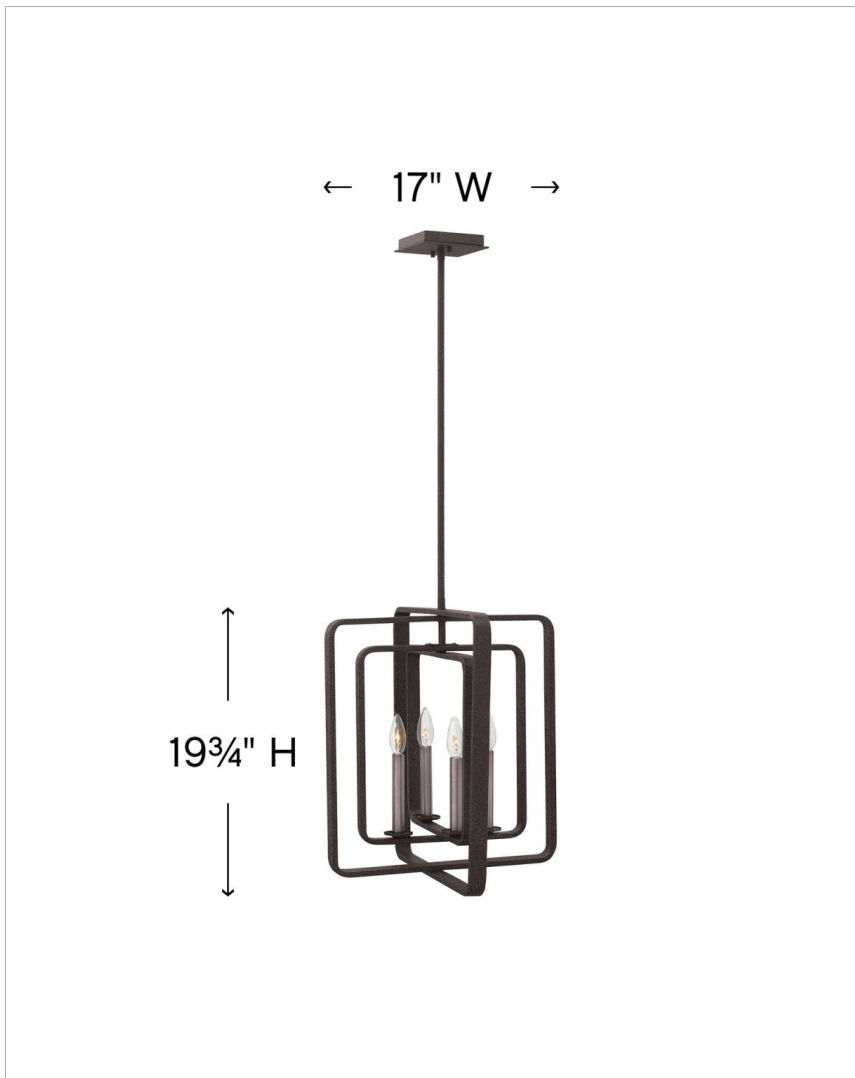

#### PRODUCT DETAILS:

- Dry Rated
- Includes (1) 6" stem and (2) 12" stems to customize hanging height
- Can be hung on a sloped ceiling
- Angular lines, a bold finish, simple shape and sturdy details merge for a robust but pared down industrial design